

Speaker Cage Assembly Instructions

Speaker cage installations are very simple. Wall bases are highly recommended for masonry wall installations as these will allow you to leave the masonry screws in place and easily remove the cage to service the speaker. For sheet rock wall construction, we recommend mounting a wood base to screw the cage brackets onto instead of using anchors in the sheet rock. Cages are designed to the speaker dimensions and not 16" centers for wall studs.

Speaker cages are designed using bolt together sections - two interchangeable side panels and a front panel, or an additional top and bottom panel for full coverage. The hardware is all supplied to do this. You will need a Philips screwdriver and a wrench (7/16 or 11mm) for the hex nuts to assemble the cage sections. For example, a 40" high cage consists of two 20" cage sections mounted vertically. The brackets for the wall attachment are designed to use 1/4" hardware.

The cages should be positioned over the speakers after the speakers swivel and tilt adjustments have been made. If the speakers are swiveled to one side, position the cage to be centered over the swiveled cage, not with the cage positioned perpendicular to the wall. Move the cage position in the direction of the swivel.

For single loudspeaker installations.

Three-Panel Cage:

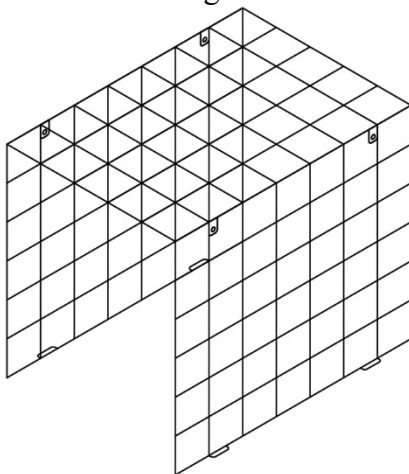

Five-Panel Cage:

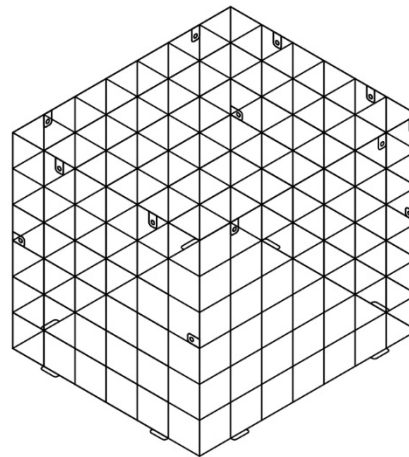

Right Panel:

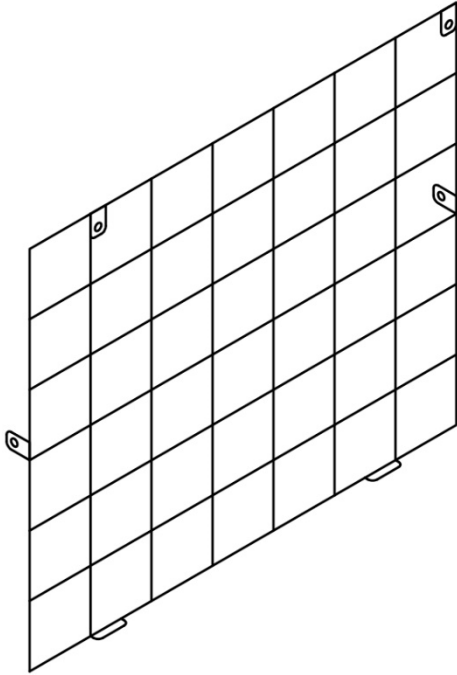

Front Panel:

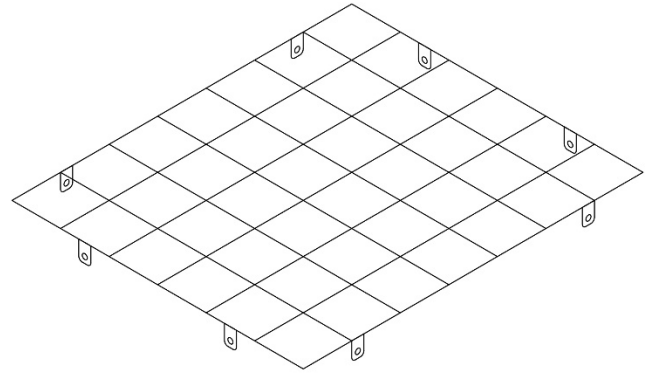

Left Panel:

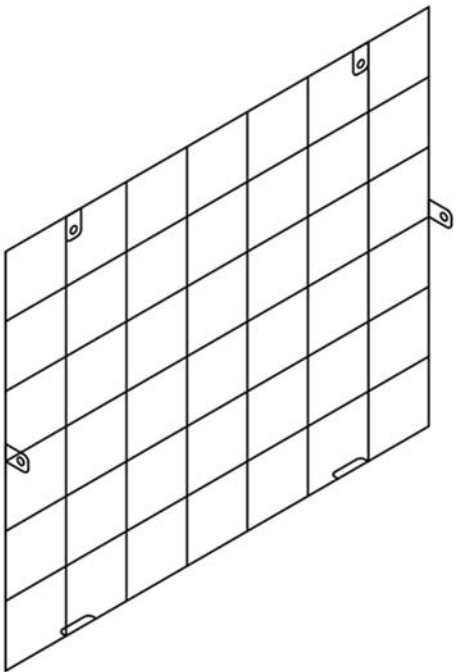

Bottom or Top Panel:

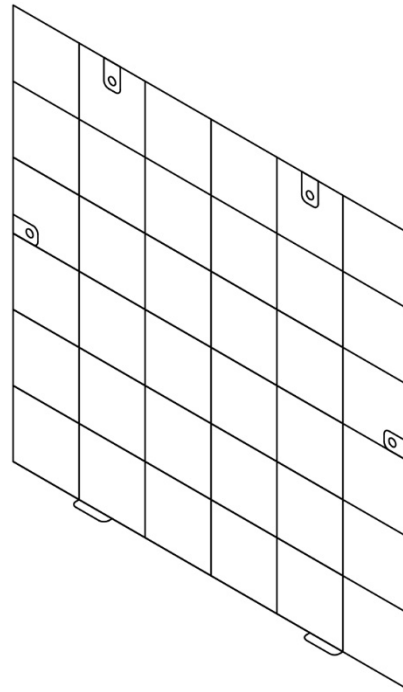

For loudspeakers stacked vertically.

Assembled Six-Panel Speaker Cage:

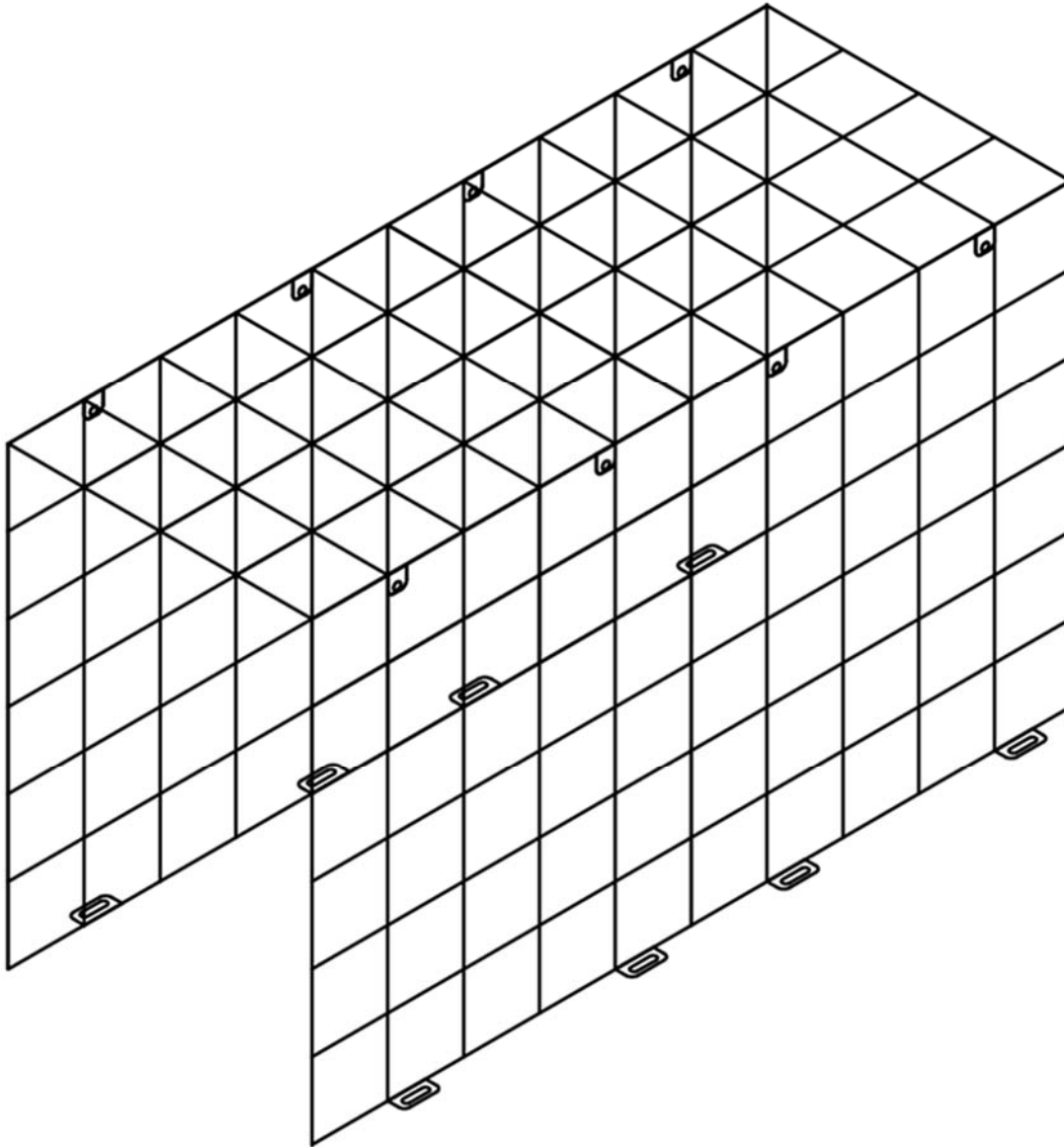

Assembled Eight-Panel Cage:

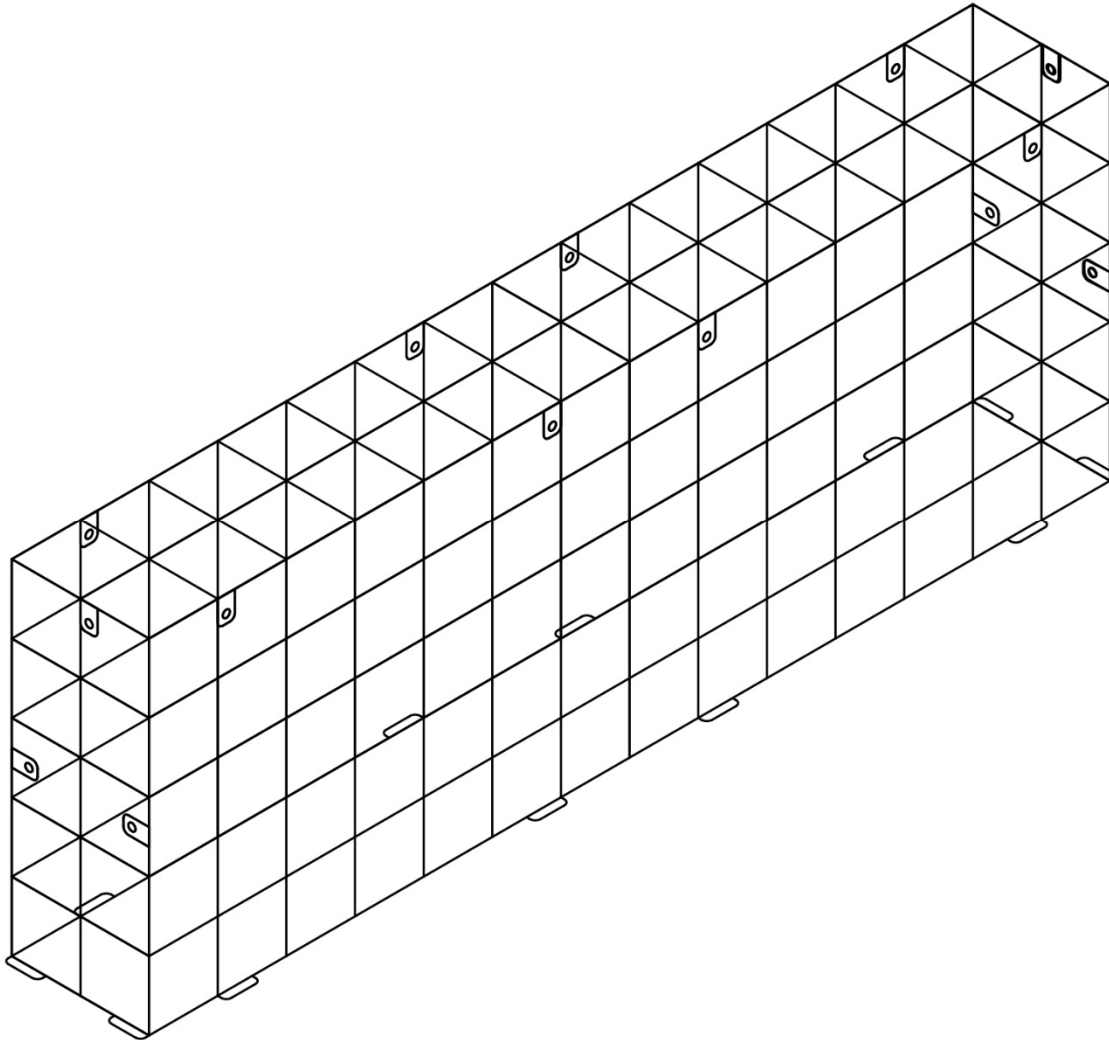

If you have any questions about installation or assembly of these speaker cages, please contact us.

joe@joesportshop.com

860-663-8017